



Food Business Guidelines:

Planning, Design, Construction & Operation

**CITY OF WANNEROO
HEALTH SERVICES**

Last Updated – July 2015

CONTENTS

1.0	Introduction	3
2.0	Legislation	3
3.0	Definitions	3
4.0	Risk Classification and Inspection Frequency	3
5.0	Fees	4
6.0	Council Requirements	4
6.1	Planning Services	4
6.2	Building Services	4
6.3	Environmental Health Services Assessment	4
6.4	Notification and Registration	5
6.5	Buying Selling or Closing a Food business	5
6.6	Initial Inspection	5
6.7	Submitting Plans	5
7.0	State Government Departments	7
7.1	Department of Racing, Gaming and Liquor	7
7.2	Department of Environment Regulation	7
7.3	Western Power and Alinta Gas	7
7.4	Water Corporation	7
8.0	Design and Construction	8
8.1	General Requirements	8
8.2	Water Supply	8
8.3	Sewage and Waste Water Disposal	9
8.4	Storage of Garbage and Recyclable Matter	10
8.5	Ventilation	10
8.6	Lighting	11
8.7	Floors	12
8.8	Walls and Ceilings	12
8.9	Fixtures, Fittings and Equipment General Requirements	13
8.10	Hand Washing Facilities	13
8.11	Storage Facilities	14
8.12	Toilet Facilities	14
9.0	Operational Requirements	15
9.1	Hot and Cold Food Storage and Display	15
9.2	Cleaning and Sanitising	15
9.3	Maintenance	16
9.4	Temperature Measuring	16
10.0	Food Vehicles	16
10.1	Food Transport Vehicles	16
10.2	Mobile Food Vehicles	16
11.0	Miscellaneous	17
11.1	Animals and Pests	17
11.2	Food Safety Training	17
11.3	Outdoor Eating Areas (Alfresco Dining)	18
12.0	Food Service to Vulnerable Persons	18
13.0	Food Preparation from a Residential Premises	18
14.0	Family Day Care Centres	18
15.0	Charities and Fund Raising Events	18
16.0	Food Labeling Requirements	18
17.0	Food Hygiene Requirements	19
18.0	Contact Details	19

1.0 INTRODUCTION

This information is provided as a general guide for owners, proprietors, self certifiers, architects and/or builders who intend to design, construct, fit-out and/or operate a food premises or food vehicle within the City of Wanneroo. This guide also details the process for notification and registration of a food business within the City.

Whilst every effort is made to ensure the information contained herein is correct, this document is provided as a guide only. Proponents are responsible for verifying compliance with legislative requirements and are encouraged to seek their own independent legal advice. The City accepts no responsibility for any consequence as the result of using this document.

2.0 LEGISLATION

Food businesses are currently governed by the following legislation:

- Food Act 2008 (the Act)
- Food Regulations 2009 (the Regulations)
- Australia New Zealand Food Standards Code (the Code)

Copies of the Act and Regulations can be downloaded at the State Law Publisher website www.slp.wa.gov.au. Copies of the Code are available at the FSANZ website www.foodstandards.gov.au. The FSANZ website also has a number of user guides to help explain the Code further.

Australian Standard (AS 4674-2004) *Design, construction and fit-out of food premises* can provide you with good detail and advice on your proposed food business. This document is copyrighted and can be purchased from SAI Global at www.saiglobal.com/search-publications.

The Western Australian Department of Health has also produced a number of useful publications for the food industry which are available at www.public.health.wa.gov.au.

3.0 DEFINITIONS

“Food Business” means a business, enterprise or activity (other than a business, enterprise or activity that is primary food production) that involves —
(a) the handling of food intended for sale; or
(b) the sale of food, regardless of whether the business, enterprise or activity concerned is of a commercial, charitable or community nature or whether it involves the handling or sale of food on one occasion only.

4.0 RISK CLASSIFICATION AND INSPECTION FREQUENCY

The City of Wanneroo uses a risk-based classification system for food businesses which is determined by the type of food prepared and who the food is prepared for (e.g. elderly people and children). Risk classification determines the initial inspection frequency but this may be altered by the outcome of the routine inspections i.e. if the inspection result is good, then the inspection frequency is lessened. If the inspection result is sub-standard then more frequent inspections of the business may be undertaken.

Food businesses are classed into:

Exempt	e.g. newsagencies selling pre-packaged not potentially hazardous goods, non-profit organisations
Low risk	e.g. bars selling beverages
Medium Risk	e.g. most cafes and restaurants will fall into this category
High Risk	e.g. food catering business, nursing homes and child care centres

5.0 FEES

New Food Businesses based within the City of Wanneroo are charged a one off Application and Registration fee at the time of lodging their application.

Food businesses registered with another local authority that are notifying the City of Wanneroo of their intention to trade within the City also pay a one off notification fee.

Food Businesses are then charged an annual fee as set each year by Council based on their level of risk. Invoices are sent out in September for the following 12 months starting on the 1 October. Where a new Food Business commences operations within July, August or September they will not be charged the annual fee in September.

For the current fee schedule please contact Environmental Health Services on 9405 5000.

6.0 COUNCIL REQUIREMENTS

6.1 Planning Services

The premises you have chosen to operate your food business from may require planning approval and a Development Application may need to be submitted to ascertain suitability with the Local Planning Scheme in relation to zoning, parking and other issues. There may be restrictions on the type of uses permitted within a building and it is important to determine if the chosen premises is suitable for your intended purpose. Obtaining Planning Approval is usually the first step in obtaining all other approvals.

Contact Planning Services on 9405 5000 for more information on the Planning Approval process.

6.2 Building Services

You will be required to seek Building approval for:

- newly constructed premises;
- where coolrooms and exhaust canopies are to be installed; and/or
- where alterations may affect the structural integrity of the building.

Contact Building Services on 9405 5000 for more information relating to Building Licences.

6.3 Environmental Health Services Assessment

Prior to seeking building approval (if applicable) and commencing construction/fit-out of your food business, it is recommended that you submit an **Application for Health Assessment** to the City's Health Services. Your application, which carries a standard fee, is assessed by an Environmental Health Officer for compliance with the above mentioned food legislation. Once assessed, you will receive a Health Assessment Certificate stating that the plans fully comply, substantially comply, or do not comply, with justifications for non-compliances in addition to recommendations. This application is not compulsory. The application form is available on the City's website by searching for "Food and Liquor" at www.wanneroo.wa.gov.au and should be submitted with the applicable fees and detailed plans and specifications of your proposed premise.

6.4 Notification and Registration

All food businesses intending to operate within the City of Wanneroo are required to notify the City of their intentions. Prior to opening you must lodge with the City's Health Services a *Food Business Notification and Registration Form* along with the associated fees and additional documentation as requested in the form. The Notification Form is used to determine the businesses overall risk rating as mentioned in Section 4.0.

Food businesses based in the City of Wanneroo will receive a **Registration Certificate**. Registration occurs once and remains in place until the business is closed, sold or the City cancels it.

Food Businesses who are deemed "Exempt" or that are registered with another local authority are not required to be registered. Upon notifying the City of Wanneroo, these businesses will receive an **Acknowledgement of Notification**. Acknowledgement of Notification occurs once and remains in place until the business ceases operation, is sold or the City cancels it.

6.5 Buying, Selling or Closing a Food Business

Food business registrations are not transferable.

If you are selling or closing a food business you must advise the City of Wanneroo and/or your local authority of the intended date you will cease to operate and your registration will be cancelled.

If you are buying an existing food premise, you must submit a *Food Business Notification and Registration Form* as a new business as mentioned above.

If you are currently registered and updating your details, such as postal address or contact number, you are not required to submit a new notification form, you can email health@wanneroo.wa.gov.au with your updates, whilst referencing the Application Number shown on your Certificate/Acknowledgement.

6.6 Initial Inspection

Once construction is complete, you will need to contact Health Services to arrange for an Environmental Health Officer to undertake an initial inspection for compliance with the relevant legislation. It is requested at least 5 days' notice is given; shorter periods may result in your preferred time being unavailable. To arrange an inspection please call 9405 5000 and ask to speak with the Environmental Health Officer for your suburb.

6.7 Submitting Plans

When submitting either of the forms above, you should include a copy of plans for the store which should indicate;

- scale – typically 1:50
- all dimensions
- floor plan
- sectional elevations through walls etc.
- hydraulic plans of fresh water and waste water services
- mechanical exhaust ventilation plan
- finishes of every wall, floor and ceiling
- the position and type of every fixture, fitting and equipment
- toilet facilities
- grease traps
- the estimated number of patrons.

NOTE: Submitted plans must be of a high quality that clearly shows all of the above details.

The following diagram is an example of the standard required:

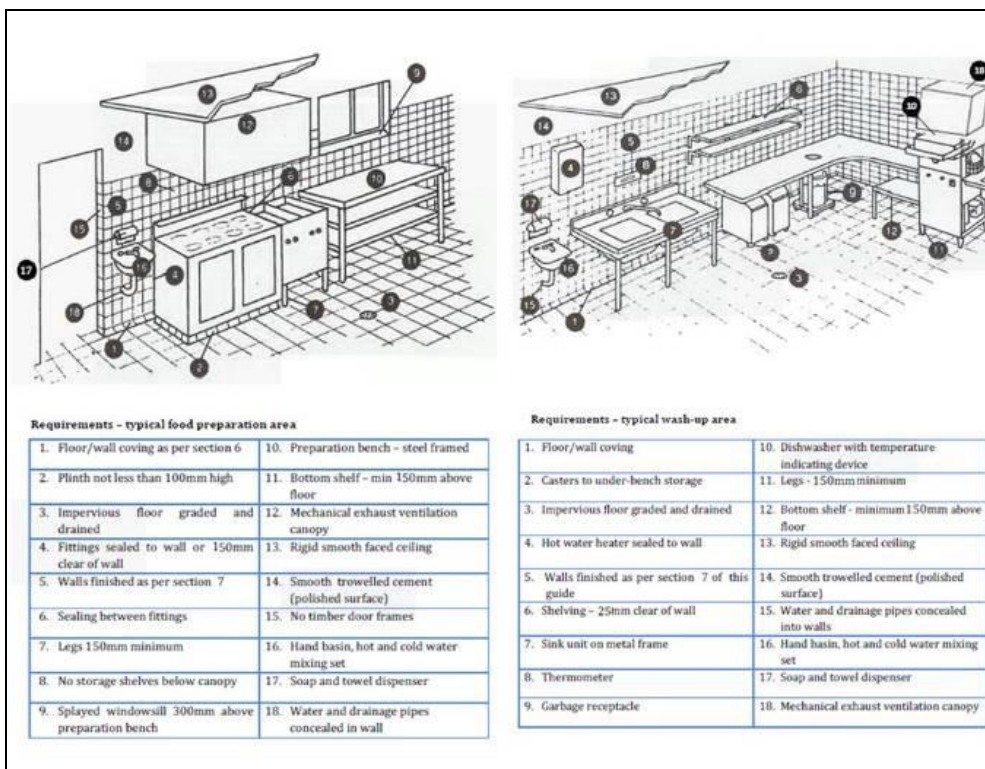
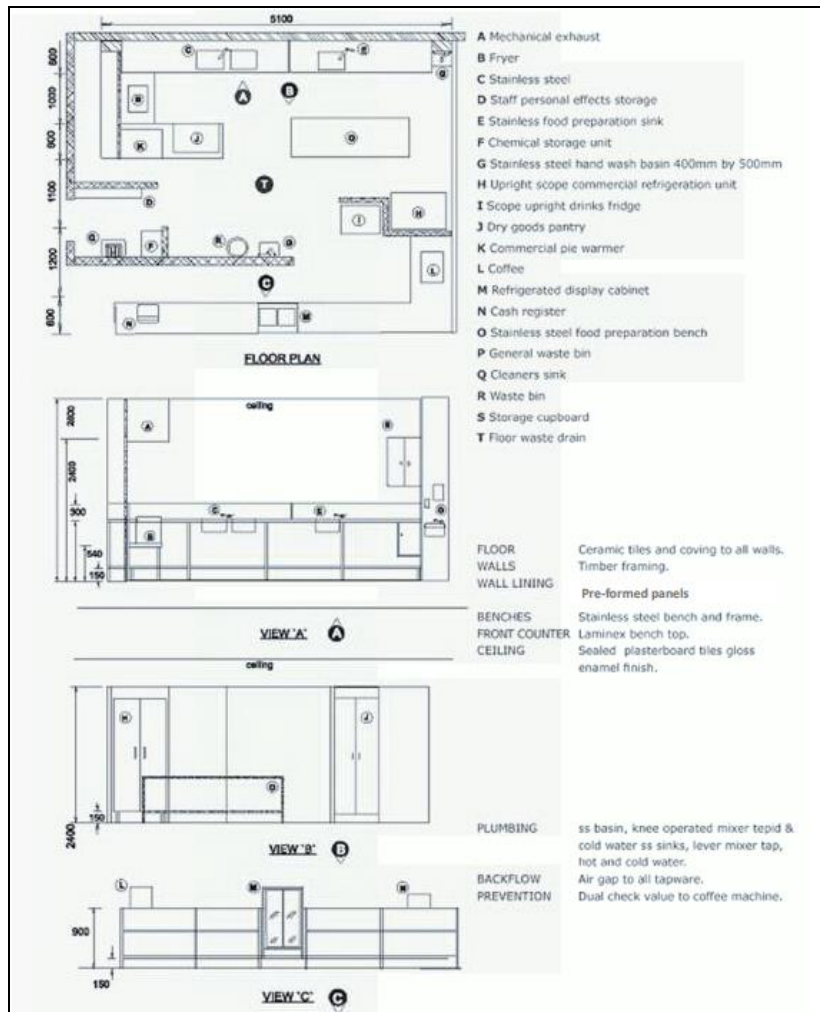

7.0 STATE GOVERNMENT DEPARTMENTS

7.1 Department of Racing, Gaming and Liquor (RGL)

Any premises selling alcohol must obtain a liquor licence. Applications for a licence can be obtained from RGL and will usually require a Section 39 certificate to be issued from Health Services. A Section 40 Certificate may also be required to be issued by Planning Services. Please contact Health Services for Section 39 application and Planning Services for a Section 40 application forms or visit the City's website at www.wanneroo.wa.gov.au. Liquor Licences are not required where a premise is a BYO only establishment.

RGL can be contacted via:

Phone: 9425 1888

Email: rql@rql.wa.gov.au

Website: www.rgl.wa.gov.au

7.2 Department of Water and Environment Regulation (DWER)

The council enforce DER legislation which deals with pollution such as noise, waste, water and air. Problems may arise due to noisy refrigeration motors and exhaust hood outlets. Consider neighbouring premises when installing such equipment. Sound levels created by the business must not exceed those in the *Environmental Protection (Noise) Regulations 1997*. New premises may be requested to submit an acoustical report verifying noise emissions are compliant.

All food businesses are required to comply with the *Environmental Protection (Unauthorised Discharges) Regulations 2004*, which requires that no discharge occurs to the environment. Measures such as having adequate drainage, refuse storage with wash down facilities, waste fat and oil storage and collection assist in preventing environmental discharge. Environmental Health Officers may issue infringements if a food business is found discharging chemicals, fats, oils etc. into the environment (e.g. stormwater drain).

DER can be contacted via:

Phone: 6364 7000

Website: www.dwer.wa.gov.au

7.3 Western Power and Alinta Gas

All electrical and gas fittings should be approved by Western Power and Alinta Gas and installed in accordance with the relevant regulations.

Western Power:

Phone: 9326 4911

Website: www.wpcorp.com.au

Alinta Gas:

Phone: 13 13 59

Website: www.alintacustomer.com.au

7.4 Water Corporation

Plumbing is to be carried out by a licensed plumber in accordance with the Metropolitan Water Supply, Sewerage and Drainage Board by-laws.

The Industrial Waste Section at the Water Corporation should be consulted for provision of grease traps. Most food premises where food preparation occurs will require a grease trap to be installed.

Phone: 13 13 95 Website: www.watercorporation.com.au

8.0 DESIGN AND CONSTRUCTION

8.1 General Requirements

The food premises must comply with the requirements of the Food Standards Code - Food Safety Standard 3.2.3 – Food Premises and Equipment (FSS 3.2.3). The additional following information may be useful when designing your food premises (follow the FSS 3.2.3 headings which match the ones below).

Your food business design must aim to:

- Exclude locations that may allow harbourage to vermin by such measures as eliminating cavities, cracks and crevices.
- Facilitate easy cleaning by measures such as providing open access to all surfaces where grease and dust may accumulate and ensuring that all surfaces are durable, smooth, impervious and washable.
- Allow the flow of food in one direction, from receipt, to storage, to preparation, to packing/serving/dispatch incorporating in the design process provision for safe food handling practices so that the risk of contamination is minimised.

Consider:

- Sufficient dining space, allowing of 1m² per person for dining area.
- Adequate kitchen area, recommended 16m² or 25% of total floor area including dining area.
- Potential for future expansion. If in the future you wish to upgrade the type of food preparation, then you may also need to upgrade the premises to suit.
- The kitchen incorporating crockery/equipment, chemical storage and cleaning equipment, dry food and packaging materials storage, chilled and frozen food storage, washing areas, wet and dry preparation areas, cooking areas, food service and office materials.
- Separation of raw products and cooked/final products.
- Sanitary conveniences for both staff and customers.
- Space for changerooms and storage area for personal items.
- Pest proofing measures such as
 - windows, serving hatches and doors with mesh screens, air curtains, plastic strip curtains and/ or self-closing mechanisms
 - installation of insect control devices
- Seal all pipes, drains, cables and ducts.

8.2 Water Supply

Relevant Food Safety Standard	Performance Criteria	Acceptable Solutions
FSS 3.2.3 Division 2 Clause 4	<p>Food premises must have an adequate supply of water if water is to be used at the food premises for any of the activities conducted on the food premises.</p> <p>A food business must use potable water for all activities that use water that are conducted on the food premises.</p> <p>Mobile food businesses must carry adequate supplies of potable water given their activities.</p>	<ul style="list-style-type: none"> ▪ Scheme water ▪ Tank and bore water (if no scheme water available - Laboratory Certification stating compliance with NHMRC Guidelines must be provided) ▪ Hot water system installed in adequate capacity for the activities occurring at the premises

8.3 Sewage and Waste Water Disposal

Relevant Food Safety Standard	Performance Criteria	Acceptable Solutions
FSS 3.2.3 Division 2 Clause 5	<p>The premises must have a sewage and waste water disposal system which:</p> <ul style="list-style-type: none"> ▪ Effectively disposes of all sewage and wastewater ▪ Is constructed and located so that there is no likelihood of the sewage and wastewater polluting the water supply or contaminating food <p><u>Mobile food vehicles:</u></p> <ul style="list-style-type: none"> ▪ Where there is no connection to mains sewer, temporary holding tanks must be installed. 	<ul style="list-style-type: none"> ▪ Connection to deep sewer ▪ If the premises is located in areas without deep sewerage you will require on-site disposal. A further application to install an apparatus for the treatment of sewage is required ▪ Contact the Water Corporation for information regarding grease traps. The City does not process these applications ▪ Wastewater generated from mop buckets, cleaning mops and other cleaning activities must be disposed of in a cleaner's sink. ▪ Equipment generating liquid waste must be connected to an approved tundish.

Design and installation of sanitary plumbing and drainage must comply with AS3500.2.2 (Plumbing and drainage – sanitary plumbing and drainage)

Typical Cleaner's Sinks

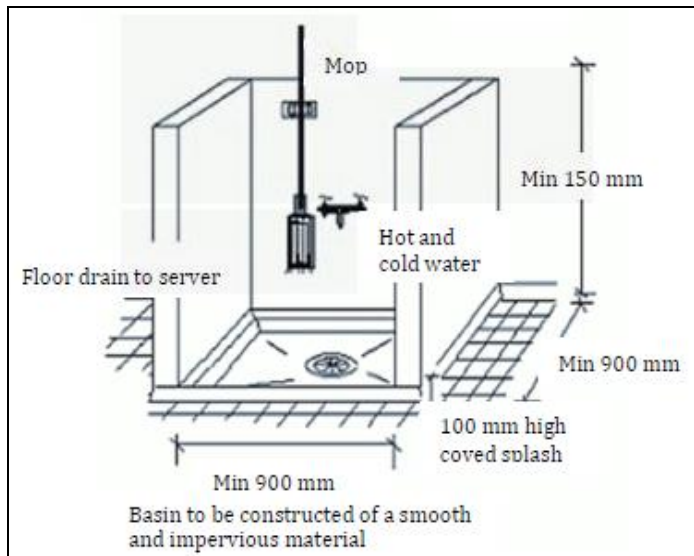
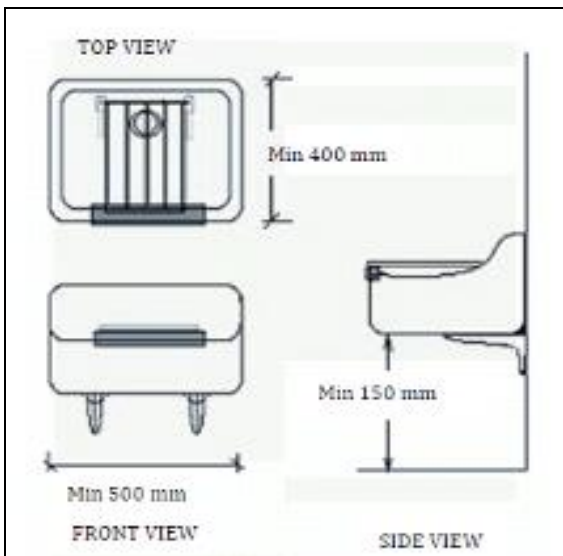

8.4 Storage of Garbage and Recyclable Matter

Relevant Food Safety Standard	Performance Criteria	Acceptable Solutions
FSS 3.2.3 Division 2 Clause 6	<p>The premises must have waste facilities that:</p> <ul style="list-style-type: none"> ▪ Adequately contain the quantity and type of waste and recyclable matter ▪ Are enclosed, as to not allow access to pests and animals (Bin Store) ▪ Are designed and constructed to be easily and effectively cleaned 	<ul style="list-style-type: none"> ▪ Provision of an adequate supply of water within Bin Store for cleaning ▪ Bin store to be provided with a floor waste drain connected to sewer or onsite effluent disposal system ▪ Refuse containers serviced by appropriate contractor ▪ Fats and oils must be stored in leak proof containers and be regularly collected by a waste removal contractor ▪ Easy access to allow for removal of bins ▪ Bins in food preparation areas should be located where cross contamination will not occur. They should be provided with a plastic liner and lid. These bins should be cleaned and sanitised regularly

8.5 Ventilation

Relevant Food Safety Standard	Performance Criteria	Acceptable Solutions
FSS 3.2.3 Division 2 Clause 7	<p>Food premises must have sufficient natural or mechanical ventilation to effectively remove fumes, smoke, steam and vapours from the food premises.</p> <p>Mechanical exhaust ventilation system to be designed, constructed and installed in accordance with AS 1668 Part 2 (2002).</p>	<p>Mechanical ventilation to be installed for:</p> <ul style="list-style-type: none"> ▪ Cooking equipment where electrical input exceeds 8kW ▪ Cooking equipment where gas input exceeds 29MJ/h ▪ All deep fryers. <p>Natural ventilation can be accepted in certain circumstances depending on the activities undertaken</p> <p>Written certification is required to verify that system meets performance criteria and is installed in accordance with Australian Standards where applicable</p>

Typical Design of Mechanical Exhaust System

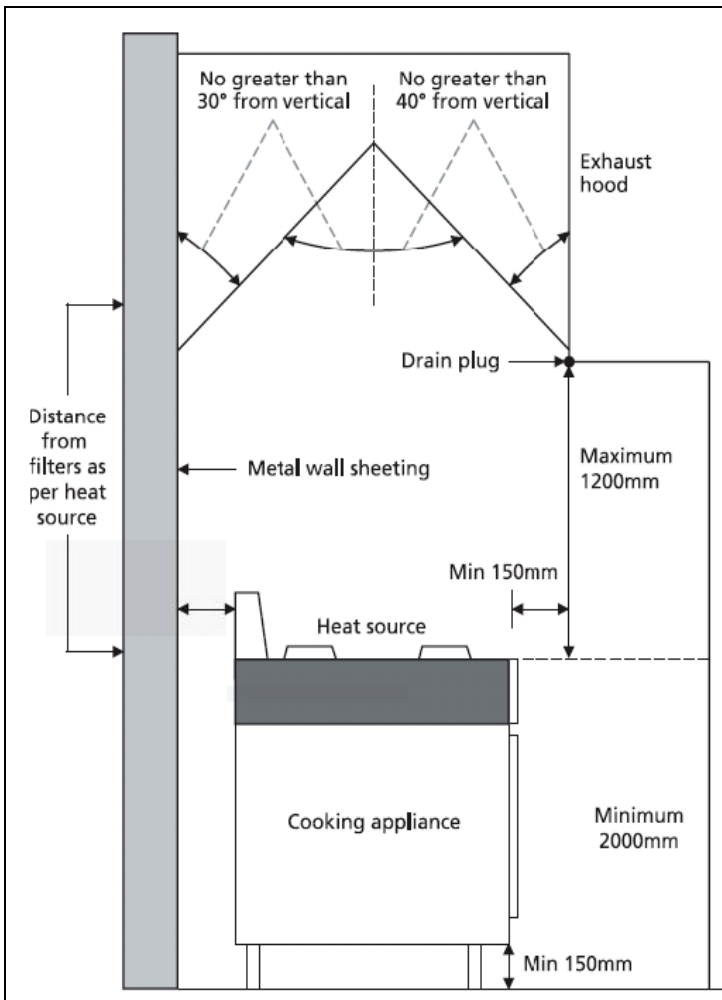

8.6 Lighting

Relevant Food Safety Standard	Performance Criteria	Acceptable Solutions
FSS 3.2.3 Division 2 Clause 8	Food premises must have a lighting system that provides sufficient natural or artificial light for the activities conducted on the food premises.	<ul style="list-style-type: none"> ▪ Natural light ▪ Artificial—recessed and diffuser ▪ Artificial—ceiling mounted and diffuser ▪ Light fittings should to be provided with protective plastic covers or sleeves to prevent contamination of food with broken glass. ▪ All fittings are able to be easily cleaned.

8.7 Floors

Relevant Food Safety Standard	Performance Criteria	Acceptable Solutions
FSS 3.2.3 Division 3 Clause 10	<p>Floors must be:</p> <ul style="list-style-type: none"> ▪ designed and constructed in a way that is appropriate for the activities conducted on the food premises. ▪ be able to be effectively cleaned; ▪ be unable to absorb grease, food particles or water; ▪ be laid so that there is no ponding of water; and ▪ to the extent that is practicable, be unable to provide harbourage for pests <p>Temporary Food Premises do not have to comply with the above if it poses no risk to the safety of the food and is approved by the City.</p>	<ul style="list-style-type: none"> ▪ Ceramic tiles ▪ Coving provided ▪ Concrete and epoxy layer ▪ Commercial grade continuous vinyl ▪ Treated concrete ▪ Flooring materials in light colour

8.8 Walls and Ceilings

Relevant Food Safety Standard	Performance Criteria	Acceptable Solutions
FSS 3.2.3 Division 3 Clause 11	<p>Walls must be:</p> <ul style="list-style-type: none"> ▪ designed and constructed in a way that is appropriate for the activities conducted on the food premises; ▪ provided where they are necessary to protect food from contamination; ▪ sealed to prevent the entry of dirt, dust and pests; ▪ unable to absorb grease, food particles or water; ▪ able to be easily and effectively cleaned. ▪ to the extent that is practicable, be unable to provide harbourage for pests. 	<ul style="list-style-type: none"> ▪ Ceramic tiles ▪ Impervious panelling ▪ Smooth finish provided ▪ Splashbacks provided to sinks and benches ▪ Heat resistant material behind cooking equipment ▪ Light coloured paint ▪ Solid, continuous construction <p>NOTE: Drop-in panel ceilings will not be approved in kitchens and food preparation areas.</p>

8.9 Fixtures, Fittings and Equipment General Requirements

Relevant Food Safety Standard	Performance Criteria	Acceptable Solutions
FSS 3.2.3 Division 4 Clause 12	<p>Fixtures and fittings are to be adequate for the production of safe food and fit for the intended use.</p> <p>Fixtures and fittings should be designed and constructed so that:</p> <ul style="list-style-type: none"> ▪ There is no likelihood of causing food contamination ▪ The fixtures and fittings and adjacent floors, walls and ceilings are able to be easily and effectively cleaned ▪ They are unable to provide harbourage for pests <p>Food contact surfaces must be:</p> <ul style="list-style-type: none"> ▪ Able to be easily and effectively cleaned and sanitised ▪ Impervious ▪ Made of material that will not contaminate the food <p>Eating/drinking utensils must be able to be easily and effectively cleaned and sanitised.</p>	<p>Fixtures, fittings, shelving and equipment should:</p> <ul style="list-style-type: none"> ▪ Be able to be easily moved ▪ Have castors fitted and flexible connections ▪ Have 150mm legs and clear of walls ▪ Be sealed to plinth, surfaces, floor and adjacent surfaces ▪ Have 75mm above bench and clear of the wall ▪ Not have false backs or bottoms ▪ Food contact surfaces of stainless steel ▪ Pipes, ducts, fitting and fixtures should be concealed in the wall, floor or ceiling <p>▪ Double bowl sink for utensil and equipment washing</p> <p>OR</p> <ul style="list-style-type: none"> ▪ Single bowl sink and dishwasher capable of sanitising <p>AND</p> <ul style="list-style-type: none"> ▪ Separate sink for fruit and vegetable washing <p>AND</p> <ul style="list-style-type: none"> ▪ Separate sink for hand washing

8.10 Hand Washing Facilities

Relevant Food Safety Standard	Performance Criteria	Acceptable Solutions
FSS 3.2.3 Division 4 Clause 14	<p>A food premises must have a designated hand wash basin that is;</p> <ul style="list-style-type: none"> ▪ Located in an easily accessible location for all food handlers ▪ Within immediate area where food handlers work ▪ Adjacent to the toilets or toilet cubicles at the food premises (if any) ▪ Be a permanent fixture ▪ Connected to or provided with a supply of warm running potable water (between 22°C and 48°C) ▪ Of a size which allows easy and effective hand washing 	<ul style="list-style-type: none"> ▪ Minimum 11 litre capacity basin ▪ Supplied with soap, paper towels and a waste container ▪ Hand Basins connected to sewer or onsite effluent disposal system

	<ul style="list-style-type: none"> ▪ Connected to approved waste water system ▪ clearly designated for the sole purpose of washing hands, arms and face 	
--	---	--

Typical Handwash Basin

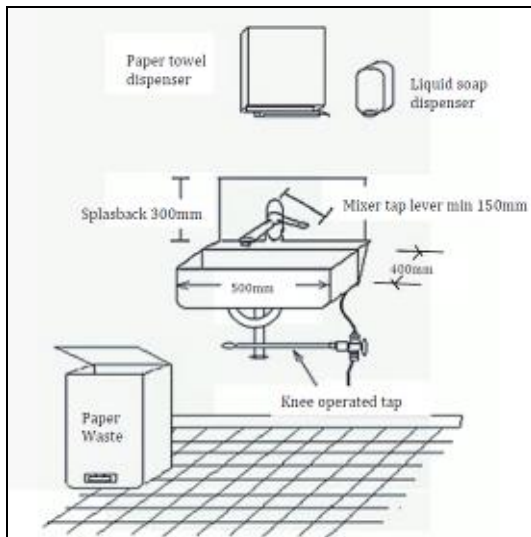

8.11 Storage Facilities

Relevant Food Safety Standard	Performance Criteria	Acceptable Solutions
FSS 3.2.3 Division 4 Clause 15	<p>Adequate storage facilities must be provided for items that are likely to contaminate food, including;</p> <ul style="list-style-type: none"> ▪ Chemicals ▪ Clothing ▪ Personal belongings <p>Storage facilities should be located where there is no likelihood of the above items contaminating food or food contact surfaces</p>	<ul style="list-style-type: none"> ▪ Separated staff room ▪ Clearly designated room, shelf or cupboard for staff items ▪ Clearly designated chemical/cleaning items storage room, shelf or cupboard

8.12 Toilet Facilities

Relevant Food Safety Standard	Performance Criteria	Acceptable Solutions
FSS 3.2.3 Division 5 Clause 16	<p>An appropriate number of toilets must be available for the use of food handlers</p>	<ul style="list-style-type: none"> ▪ Number as determined by Building Code of Australia ▪ A disabled facility must be provided in newly constructed premises and may be required when alteration, additions or a change of use are undertaken on an existing property

		<ul style="list-style-type: none"> ▪ Gender identification signs are required on the toilet doors ▪ Sanitary disposal facilities are required in female toilets ▪ Patron sanitary conveniences are generally only required when a food premises accommodates more than 20 persons
--	--	--

9.0 OPERATIONAL REQUIREMENTS

9.1 Hot and Cold Food Storage and Display

Relevant Food Safety Standard	Performance Criteria	Acceptable Solutions
FSS 3.2.2 Division 3 Clause 6 & 8	<p>During storage and display, food must be;</p> <ul style="list-style-type: none"> ▪ Protected from the likelihood of contamination ▪ When storing potentially hazardous food must be under appropriate temperature control ▪ Frozen food to remain frozen 	<ul style="list-style-type: none"> ▪ Hot display unit minimum of 60°C ▪ Cold display Unit/Cool Room maximum of 5°C ▪ Freezer units maximum -15°C and food must remain frozen ▪ When displaying unpackaged ready to eat food ensure the display is effectively supervised ▪ Provide separate serving utensils for dispensing of food ▪ Provide sneeze barriers where appropriate

9.2 Cleaning and Sanitising

Relevant Food Safety Standard	Performance Criteria	Acceptable Solutions
FSS 3.2.2 Division 5 Clause 20	<p>All equipment and utensils must be kept in a clean and sanitary state.</p> <p>Heat and/or chemicals must be applied to equipment and utensils so that the number of micro-organisms on the surface has been reduced to a level that;</p> <ul style="list-style-type: none"> ▪ Does not compromise the safety of the food which it may come in contact with ▪ Does not permit the transmission of infectious disease 	<p><u>Cleaning</u></p> <ul style="list-style-type: none"> ▪ Sink (water at 54°C and detergent) ▪ Dishwasher (water at 75°C or water at 54°C and detergent) ▪ Glass washer (water at 54°C and detergent) <p><u>Sanitising</u></p> <ul style="list-style-type: none"> ▪ Chemical sanitizer, labelled as food grade ▪ Water at 77°C for hot water sanitising at the sink ▪ Rinsing compartment should be provided with heating elements capable of maintaining the water at a minimum temperature of 77°C

9.3 Maintenance

Relevant Food Safety Standard	Performance Criteria	Acceptable Solutions
FSS 3.2.2 Division 5 Clause 21	A food premises must maintain the premise and all fixtures, fittings and equipment in a good state of repair and working order.	<ul style="list-style-type: none"> ▪ Any defects are to be rectified ▪ Chipped, broken or cracked eating, drinking or food handling utensils not to be used

9.4 Temperature measuring

Relevant Food Safety Standard	Performance Criteria	Acceptable Solutions
FSS 3.2.2 Division 6 Clause 22	A food premises must have a temperature measure device that can accurately measure the temperature of potentially hazardous food to +/- 1°C	<ul style="list-style-type: none"> ▪ Thermostat and gauge provided on all units (ie display cabinets and coolrooms) <p>AND</p> <ul style="list-style-type: none"> ▪ Single mobile device per premises (i.e. Probe thermometer)

10.0 FOOD VEHICLES

10.1 Food Transport Vehicles

Relevant Food Safety Standard	Performance Criteria	Acceptable Solutions
FSS 3.2.3 Division 4 Clause 17	<p>Food Transport Vehicles must be:</p> <ul style="list-style-type: none"> ▪ Designed and constructed to protect food if there is a likelihood of contamination during transport ▪ Designed and constructed to be easily and effectively cleaned and if necessary, sanitised 	<ul style="list-style-type: none"> ▪ Smooth impervious surfaces to the storage compartment ▪ Food is to be transported in such a way as to prevent contamination (e.g. packaged in food grade storage containers) ▪ When transporting potentially hazardous food must be under appropriate temperature control

10.2 Mobile Food Vehicles

Mobile Food Vehicles are required to comply with the Code. Acceptable solutions to compliance are:

- Food handling area must be separate from the driving area
- Hand wash basin must be of adequate size, connected to a holding tank of sufficient size to contain all waste water and have a supply of liquid hand soap and single use paper towels at all times
- Utensil washing sink to be provided **in addition to hand wash basin** and connected to water holding tank, unless otherwise approved.
- Holding tank must be located beneath the vehicle and all waste water disposed of to sewer
- Vehicles must be designed and constructed so food is protected from contamination

- Vehicles must be designed and constructed so they can be easily cleaned and sanitized
- Potentially hazardous food to be maintained under appropriate temperature control
- No animals are permitted to enter the food vehicle at any time

Typical Floor Layout and Elevation of Mobile Food Vehicle

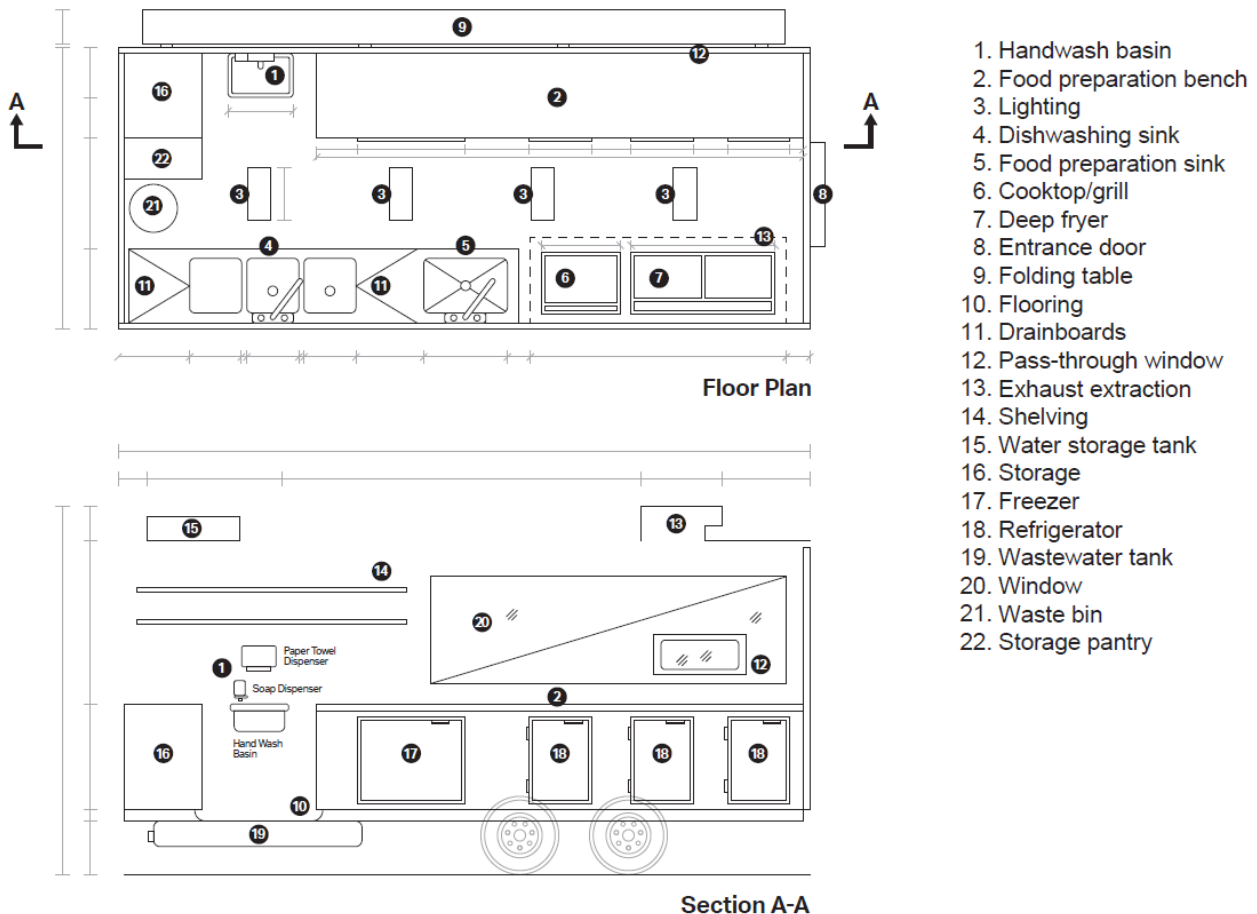

Where mobile food vehicles wish to operate within the City of Wanneroo they may be required to obtain a Trading in Public Places Licence. Please contact Health Services regarding obtaining a licence on 9405 5000.

11.0 MISCELLANEOUS

11.1 Animals and Pests

- An assistance animal, such as a guide-dog, is only permitted in dining and drinking areas
- Animals are permitted in outdoor alfresco areas at the discretion of the food premise and provided it has procedures in place to manage any food safety risks posed by the animals
- All openings should be protected as far as is practicable from pests through the use of screens, self-closing doors and other inhibiting mechanisms (e.g. air-curtains, fly-strips or fly zappers – fly-zappers must not be located over food contact surfaces)
- It is highly recommended to obtain the services of a qualified pest controller to carry out quarterly inspections and treatment for pests such as cockroaches and rodents

11.2 Food Safety Training

- It is a requirement that all food handlers demonstrate their skills and knowledge appropriate to the level of food handling that they are employed to carry out. To achieve this requirement the City of Wanneroo highly recommends that all food handlers receive food safety training prior to handling food for sale to the public
- The City's Health services offers a free online food safety training program available from the city's website www.wanneroo.wa.gov.au called I'm Alert
- For further information about available training options please contact the City's Health Services on 9405 5000

11.3 Outdoor Eating Areas (Alfresco Dining)

- An Outdoor Eating Area is licensed by the City of Wanneroo where the dining area falls onto the City's land
- Contact Health Services on 9405 5000 to obtain an application form and copy of the Local Laws relating to Outdoor Eating Areas

12.0 FOOD SERVICE TO VULNERABLE PERSONS

Food service to vulnerable persons such as hospital patients, meals-on-wheels clients, nursing homes, respite centres, children 4 years of age or less in child day care and similar services are required under Standards 3.2.1 and 3.3.1 of the Code to have a Food Safety Program. This documents how the food business will control the food safety hazards associated with food handling activities of the business. Food Safety Programs are required to be approved by the City of Wanneroo and then independently audited at a frequency determined by the City.

Where less than six vulnerable persons are serviced a Food Safety Program is not required. Premises are still required to have appropriate food premises, equipment, safety practices and comply with the other general requirements of the Code.

For more information regarding Food Safety Plans please contact the City's Health Services on 9405 5000

13.0 FOOD PREPARATION FROM A RESIDENTIAL PREMISE

Food businesses are permitted to operate from a residential premise where approved by the City of Wanneroo. Residential kitchens must still comply with the Food Standards Code in respect to Standards 3.2.2 Food Safety Practices and General Requirements and 3.2.3 Food Premises and Equipment. While these standards can require suitable high quality finishes and equipment fit-out in commercial premises, a residential kitchen undertaking low risk activities would not be expected to have the same level of fit-out.

However, should the business be rated medium or high risk, the nature of what is intended to be prepared/cooked is deemed inappropriate for a residential kitchen, then a commercial level fit-out would be expected, including ventilation, grease traps and finishes.

14.0 FAMILY DAY CARE CENTRES

If you run a family day care centre from a residential premise you must notify the council. If you are preparing food for consumption by children you must notify and register.

If you do not undertake any food preparation and merely serve food provided by the guardians then you may be deemed as an exempt food premise. You must still notify but are exempt from fee payment. An Environmental Health Officer will assess your application to determine if you fall into the exempt category.

15.0 CHARITIES AND FUND RAISING EVENTS

Food businesses which are conducted solely for charitable or community purposes and prepare non potentially hazardous foods or foods that, after being appropriately cooked, are served for immediate consumption are exempt from some of the legislative requirements. They are not required to be registered, although they must still notify the City.

16.0 FOOD LABELLING REQUIREMENTS

When you prepare food you are responsible for ensuring that the food you prepare is safe to eat and suitably labelled. Please refer to the *Australian New Zealand Food Standards Code* Part 1.2 for more information on labelling requirements which can be found at www.foodstandards.gov.au. The Department of Health has also produced guidelines and information sheets which may be of assistance at www.public.health.wa.gov.au.

17.0 FOOD HYGIENE REQUIREMENTS

- Premises must be maintained in a clean and hygienic condition and all fixtures, fittings and equipment should be well maintained.
- Domestic animals are not permitted in the food preparation area at any time.
- Enclosed shoes, clean clothing and hats must be worn during food preparation.
- Adequate rubbish disposal facilities must be provided and maintained in a sanitary condition.
- Smoking is not allowed in the kitchen.
- Easy access to a wash hand basin, with hot and cold water, liquid soap and paper towels must be provided at all times.
- The food preparation area must be provided with hot and cold water at all times. It is preferable that a double bowl sink be available for use (one for cleaning and another for food preparation).
- Adequate refrigeration must be provided to ensure that all high risk foods such as eggs and dairy products are stored at or below 5°C. Frozen food products should be stored so that they are maintained hard-frozen.
- Raw and cooked food must be stored and handled separately to prevent cross contamination. Furthermore all food must be completely covered when being stored.
- Preparation and cooking of food is only to take place when children and other persons not employed in the food business are not in the food preparation area.
- Packaging of food products to comply with the requirements of the *Australia New Zealand Food Standards Code*.
- Food preparation must only be undertaken by persons who have sufficient knowledge of food safety principles.
- Further information on food safety can be found here:
<http://www.foodstandards.gov.au/foodsafety/standards/Pages/Food-safety-requirements.aspx>

18.0 CONTACT DETAILS

Additional information, including application forms, fact sheets and guidelines on food handling and food safety, may be found on the following websites;

- Department of Health – www.public.health.wa.gov.au
- Food Standards Australia New Zealand – www.foodstandards.gov.au
- City of Wanneroo – www.wanneroo.wa.gov.au

Should you have any queries regarding food preparation, please contact the City of Wanneroo's Health Services.

General Enquiries: 9405 5000
In Person: City of Wanneroo Administration Centre, 23 Dundobar Road, Wanneroo
By Mail: Locked Bag 1, Wanneroo WA 6946
By Email: health@wanneroo.wa.gov.au